



# Industrial Water Systems

Products & Company Brochure

aerospace  
climate control  
electromechanical  
**filtration**  
fluid & gas handling  
hydraulics  
pneumatics  
process control  
sealing & shielding



ENGINEERING YOUR SUCCESS.

# Parker Sea Recovery: Three Decades of Proven Performance

Since its inception more than 30 years ago, Parker Sea Recovery has evolved into the world's leading watermaker manufacturer. Today, it is recognized globally for providing outstanding reverse-osmosis products, service and support to a broad scope of markets that includes commercial marine; offshore; oil and gas; military; and land-based organizations.

Dedicated to developing the most advanced industrial watermakers in its markets, Parker Sea Recovery engineers watermakers that are easy to use and maintain, yet are robust enough to withstand even the most challenging environmental conditions. Parker Sea Recovery systems offer advanced features including full-color touch screens, oil-free pumps, intelligent software and standard MODBUS communications that allow customers full system control and monitoring from a remote location.

Each Parker Sea Recovery system is backed by a global network of agents, distributors and service dealers, all focused on exceeding customer expectations.

## **Service-focused global network**

Parker Sea Recovery customers are supported by a global network of factory-trained technicians that stand ready to deliver outstanding maintenance and repair, wherever and whenever a need occurs. In addition, Parker Sea Recovery distribution and service partners have experienced, helicopter-certified technicians capable of handling repair and maintenance requests, no matter the location.

## **Expedited worldwide delivery**

Parker Sea Recovery stocks and manages an impressive inventory of replacement parts and consumables that are all tested and ready to ship as needed to any part of the world.

Whether it's an emergency situation or a tight schedule, customers can count on Parker Sea Recovery to get the job done. With a LEAN manufacturing facility that is able to deliver on short notice, Parker Sea Recovery can provide most single systems less than a month from the date of purchase.

## **Intuitive technology**

Nearly all Parker Sea Recovery systems are designed to be completely automated. Water production runs smoothly without the need of an operator, reducing overhead expense. Self-cleaning features and options minimize maintenance needs and prolong the life of the watermaker.



# A Solid Past, An Exciting Future

A leader in reverse-osmosis technology joins a leader in innovative engineering

As part of Parker Hannifin – recognized worldwide for excellence in product engineering across a number of industries, including reverse-osmosis systems for clean-water applications – Sea Recovery brings its own legacy of reverse-osmosis engineering excellence to the Parker organization. Now known as Parker Sea Recovery, the division operates in 48 countries, providing customers with outstanding, situation-specific solutions to their unique watermaker needs.



Parker Headquarters,  
Cleveland, Ohio, USA

Parker Sea Recovery products are tested & certified to comply with all pertinent environmental and global safety standards.

Parker Sea Recovery has been approved by commercial and industrial independent product safety standards including UL, IEC and CE. Parker Sea Recovery is also compliant with ISO 9001:2008 and ISO 14001:2004 standards and meets the criteria for ABS Type Approval.

Parker Sea Recovery continuously improves its products as it maintains best-in-class business practices designed to safeguard the environment, including:

- Manufacturing and distribution efforts that not only reduce pollution but also result in continuous and measurable improvements to the environment;
- Production processes that are sensitive to the individual employee, the work environment and the surroundings;

- Production facilities that comply with ISO 14001 standard, local environmental and work environment legislation.

## Conformance to Global Standards and Requirements

Parker Sea Recovery products and processes adhere to global standards and requirements such as ATEX, NORSOK, IEEE and NEC.

Strict compliance with these global standards means customers can have confidence in the functionality and integrity of every Parker Sea Recovery product and service they purchase. Not only does conformance ensure that all system components meet established criteria for reliability and safety, but it also bolsters the quality and effectiveness of the overall Parker Sea Recovery system.



# The Parker Sea Recovery Pledge

## Valued customers

Parker Sea Recovery endeavors to delight its customers by providing products, service and support that meet or exceed each client's unique situation. By partnering with customers, Parker Sea Recovery can better discover and respond to the circumstances of each order. Ultimately, this approach means Parker Sea Recovery delivers performance-specific systems that not only address job circumstances, but also help support real and measurable productivity and profitability.

## Code of conduct and ethical business practices

Parker Sea Recovery's solid industry reputation and good name – as well as the company's history of success – rests on a foundation made strong by thousands of dedicated Parker employees. Each of these professionals takes seriously a commitment to act responsibly and with integrity throughout every aspect of their work, from design and engineering through sales and support.

## Promoting a safe, productive workplace

Parker Sea Recovery is committed to providing a healthy and safe working environment for each of its employees. Further, employees are charged with following all health and safety rules that apply to their jobs, and for taking all reasonable precautions to protect themselves and co-workers from accidents, injuries or unsafe conditions. This pledge to health and safety includes encouraging employees to report any unsafe practices or conditions so that those can be expediently remedied.

## The environment

A leader in environmental stewardship, Parker Sea Recovery continually improves its product design and its manufacturing processes to benefit customers, suppliers, employees and shareholders as well as its local and global communities. Constantly striving to comply fully with all applicable environmental laws, Parker Sea Recovery is dedicated to safeguarding the environment in and around plants and properties.

## Supplier pre-qualification

Parker Sea Recovery understands the vital role that suppliers play in the

satisfaction of its end users.

As an extension of its own operations, Parker Sea Recovery charges its suppliers to provide materials, products and services that meet or exceed the requirements of contracts, applicable specifications and quality standards. In addition, Parker Sea Recovery requires that suppliers adhere to a strident code of conduct addressing ethical, legal, environmental and social responsibilities, further bolstering customer confidence in Parker Sea Recovery products and services.



# Parker Sea Recovery System Benefits

With features such as intuitive controls, versatile design, automated self-maintenance and energy efficiency, Parker Sea Recovery's watermakers can accommodate a spectrum of conditions and circumstances, making them an ideal fit for nearly any industry need.

## Modern user interfaces

Parker Sea Recovery user interfaces are certified to perform under even the most demanding conditions. They offer innovative industrial PLC controls featuring integrated performance-monitoring software. These features enable real-time remote monitoring of process instrumentation and system performance, as well as remote notification of detected system errors and detailed maintenance requests. Parker Sea Recovery systems are easy to operate with one-touch automatic start up and shutdown functions.

Parker Sea Recovery's watermaker systems offer versatility in design to accommodate a range of needs. Product lines include compact configurations with a minimal footprint as well as modular configurations with design flexibility to fit virtually any type of space restriction.

## Energy savings

Energy savings and self maintenance are vital features of Parker Sea Recovery's line of watermakers. Automated fresh-water flushes prolong system life and maintain performance integrity, while water-lubricated pumps require little to no maintenance, reducing repair expense and down time.

Parker Sea Recovery's largest production system, the Atlantic Sea, uses the I-Save energy

recovery pump, which can curtail energy consumption by up to 49 percent. This energy savings helps reduce running costs – and the vessel's carbon footprint.

Engineered to withstand nearly any type of condition, Parker Sea Recovery's line of commercial systems are a recognized standard in the production of clean water.

## Containerized solutions

Ideally suited for oil and gas production, mining, military applications and disaster relief situations as well as for a variety of land-based applications where pre-configured structures must comply with environmental and logistical conditions, Parker Sea Recovery containerized systems are pre-assembled and fully

tested to ensure integrity and reliability. These turnkey products offer a plug-and-play solution for challenging circumstances.

## Technical water capabilities

Parker Sea Recovery dual-pass watermakers are engineered to meet the most demanding requirements. Blending superior performance with full code compliance, Parker Sea Recovery's unique designs can provide potable and technical water from the same skid, minimizing the system footprint while improving power efficiency and lowering the total cost of ownership.

For applications where contaminants result in deposits, corrosion and carryover, Parker Sea Recovery offers reverse-osmosis systems featuring electrode-deionization mixed-bed ion exchange (MBDI) to product the highest quality demineralized water.

Parker Sea Recovery uses standard modules that can be custom engineered to deliver optimum performance and reliability.

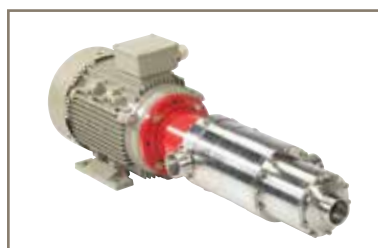

Above: System control and color touch screen. Below: I-Save Energy Recovery Pump

# Reverse Osmosis Filtration: Advantages

Reverse osmosis effectively removes 99.98 percent of all impurities from water, and is much safer than evaporation in eliminating contaminants. Parker Sea Recovery water purification systems feature high-yield, low-tolerance membranes with pores that are approximately 0.0001 micron. These membranes

successfully eliminate the harmful effects of lead, heavy metals, chlorine, chemical contaminants, pesticides, pathogens, bacteria, viruses and radioactive materials.

Integrated pre- and post-filtration processes, when coupled with the option to disinfect water using a UV

Disinfection System, makes Parker Sea Recovery system water the safest water produced.

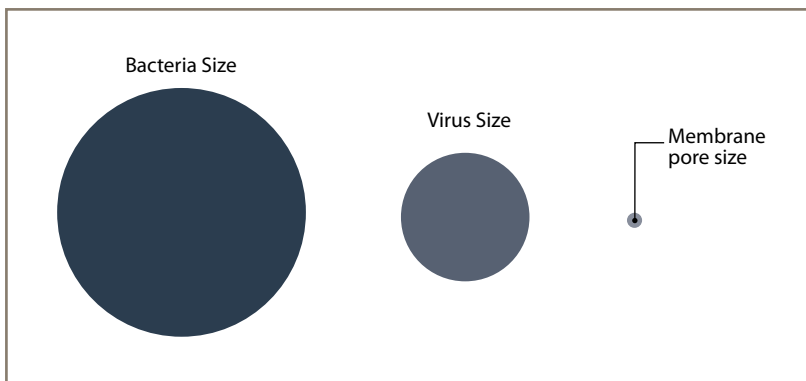

Comparison between bacteria and virus and Parker Sea Recovery's membrane pore size.

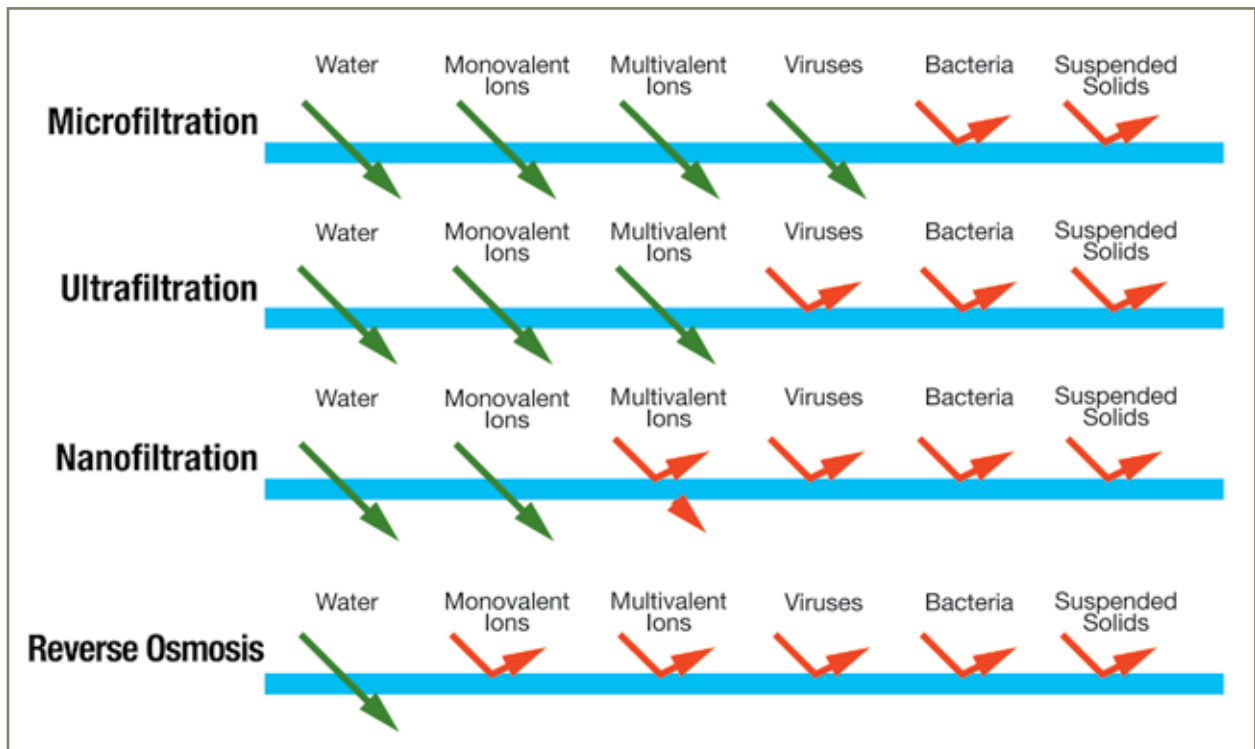

Membrane Process Characteristics

# Table of Contents

|                                     |              |
|-------------------------------------|--------------|
| <b>Industrial Series Controller</b> | <b>8-9</b>   |
| <b>Small Footprint Systems</b>      | <b>10-13</b> |
| Java Sea Series                     | 10           |
| Coral Sea Series                    | 12           |
| <b>High Capacity Systems</b>        | <b>14-19</b> |
| Tasman Sea T-2 Series               | 14           |
| North Sea Modular Series            | 16           |
| North Sea N-2 Series                | 18           |
| <b>Mega Production</b>              | <b>20-21</b> |
| Atlantic Sea Series                 | 20           |
| <b>Custom Systems</b>               | <b>22</b>    |
| <b>Accessories</b>                  | <b>23</b>    |



# Industrial Series Controller

Three configurations for a variety of needs



The Parker Sea Recovery industrial controller is an innovative solution for beginning and experienced water-system operators.

## Basic semi-automatic control system

Prevent potential problems with performance monitoring that automatically shuts down when the product tank is full. The touch-screen interface is able to display multiple warning messages that aid in basic maintenance, extending the life of the water system.

## Digital control system

A multi-colored touch-screen interface displays maintenance alerts and provides an on-screen help guide. The system also performs automatic start-ups and shutdowns depending on the level of water in the product tank.

## Fully automatic control system

This truly automated configuration practically eliminates the need for an operator. Its MODBUS communications package integrates with hosted control systems that allow remote monitoring, ensuring smooth operation.



Basic Control System



Digital Control System



Interior door / electrical



# Controller Features

## Basic controller standard features

- 101.6mm touch screen interface
- Single point tank level control
- Product salinity monitoring
- Multiple warning messages
- Performance monitoring and alerts
- Automatic start up / shut down function
- Optional basic MODBUS communication package

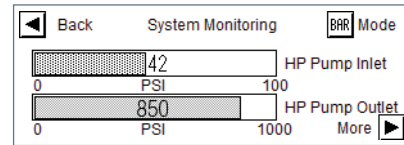

(System pressure monitoring screen)

## Digital controller standard features

Includes all basic control standard features plus:

- 203.2mm 65K color touch screen interface
- Digital display of all system pressures, flow rates automated valve positions, and filtration system blockages
- Maintenance detection and interactive on-screen help
- Multi-point tank level control
- Chemical injection controls
- Optional multi media filter automation
- Optional full MODBUS communication package

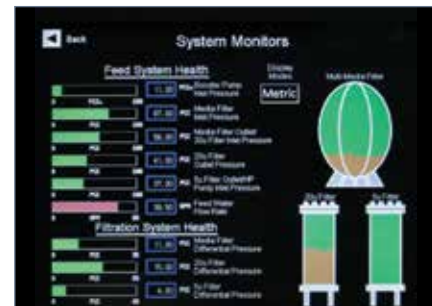

## Fully automatic controller standard features

Includes Basic and Digital control standard features plus:

- Automatic fresh water flush
- Automatic media filter backwash
- Automatic pre and post-treatment
- Automatic system pressure regulation
- Automatic back pressure regulation
- Filter element blockage prediction
- Full MODBUS communications package

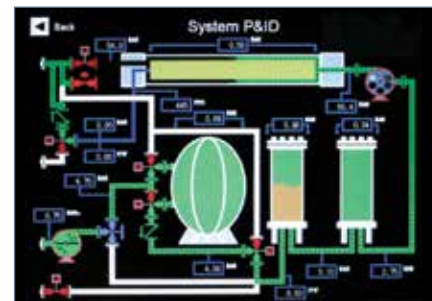

## Available Voltages

| Phase                | Three       | Three       | Three       | Three       | Three       | Three       |
|----------------------|-------------|-------------|-------------|-------------|-------------|-------------|
| Hz                   | 50          | 50          | 50          | 60          | 60          | 60          |
| VAC                  | 220         | 380         | 440         | 208         | 230         | 460         |
| FLA                  | 35          | 35          | 35          | 30          | 30          | 30          |
| Circuit Breaker Size | 125 Amperes | 100 Amperes | 100 Amperes | 125 Amperes | 125 Amperes | 100 Amperes |

# Java Sea Series

Large capacity production, small footprint



Parker Sea Recovery's revolutionary Java Sea is engineered to be easier to use and more reliable than conventional watermakers. Featuring the latest technology, the Java Sea is able to regulate and monitor system functions without the need of an operator. With one touch, the Java Sea will start and finish water production automatically.

## Automated functions

Standard watermakers require pressure adjustments for water conditions and to produce fresh water - a process that can be very time consuming. Parker Sea Recovery solves this problem by incorporating an automatic pressure regulating system into the Java Sea, allowing the watermaker to balance pressure levels automatically. This feature maximizes operator comfort and convenience.

## Longer lifespan, minimal maintenance

The Java Sea's features allow operators to extend its service life. The automatic fresh-water flush and LCD monitoring system optimizes pre-filter and membrane performance. This system will flush every seven days, whether the watermaker is producing water or on standby.



## Product features

- **Maximum production:**  
3.5 to 12 cubic meters per day (24 hours)
- **Automatic pressure regulating system**
- **High-efficiency booster pump for extended pre-filter life**
- **Automatic fresh-water flush**
- **One-touch operation**
- **Intuitive, full-color LCD touch screen interface**

## Java Sea System Specifications

| Model             | Vessel Size | Membrane Config. | Production Per Hour | Production Per 24 Hrs. | Weight |
|-------------------|-------------|------------------|---------------------|------------------------|--------|
| 3.5m <sup>3</sup> | 76.2mm      | Single           | 0.14 m <sup>3</sup> | 3.5 m <sup>3</sup>     | 195 kg |
| 7m <sup>3</sup>   | 76.2mm      | Single           | 0.29 m <sup>3</sup> | 7 m <sup>3</sup>       | 195 kg |
| 10m <sup>3</sup>  | 76.2mm      | Single           | 0.41 m <sup>3</sup> | 10 m <sup>3</sup>      | 195 kg |
| 12m <sup>3</sup>  | 76.2mm      | Single           | 0.5 m <sup>3</sup>  | 12 m <sup>3</sup>      | 195 kg |

## Electrical Requirements

| Power              | HP Pump | Booster Pump | FLA |
|--------------------|---------|--------------|-----|
| 220 / 50 Hz / 1 PH | 3.7 KW  | .75 KW       | 39  |
| 230 / 50 Hz / 1 PH | 3.7 KW  | .75 KW       | 32  |
| 220 / 50 Hz / 3 PH | 3.7 KW  | .75 KW       | 29  |
| 380 / 50 Hz / 3 PH | 3.7 KW  | .75 KW       | 15  |

## Java Sea Dimensions

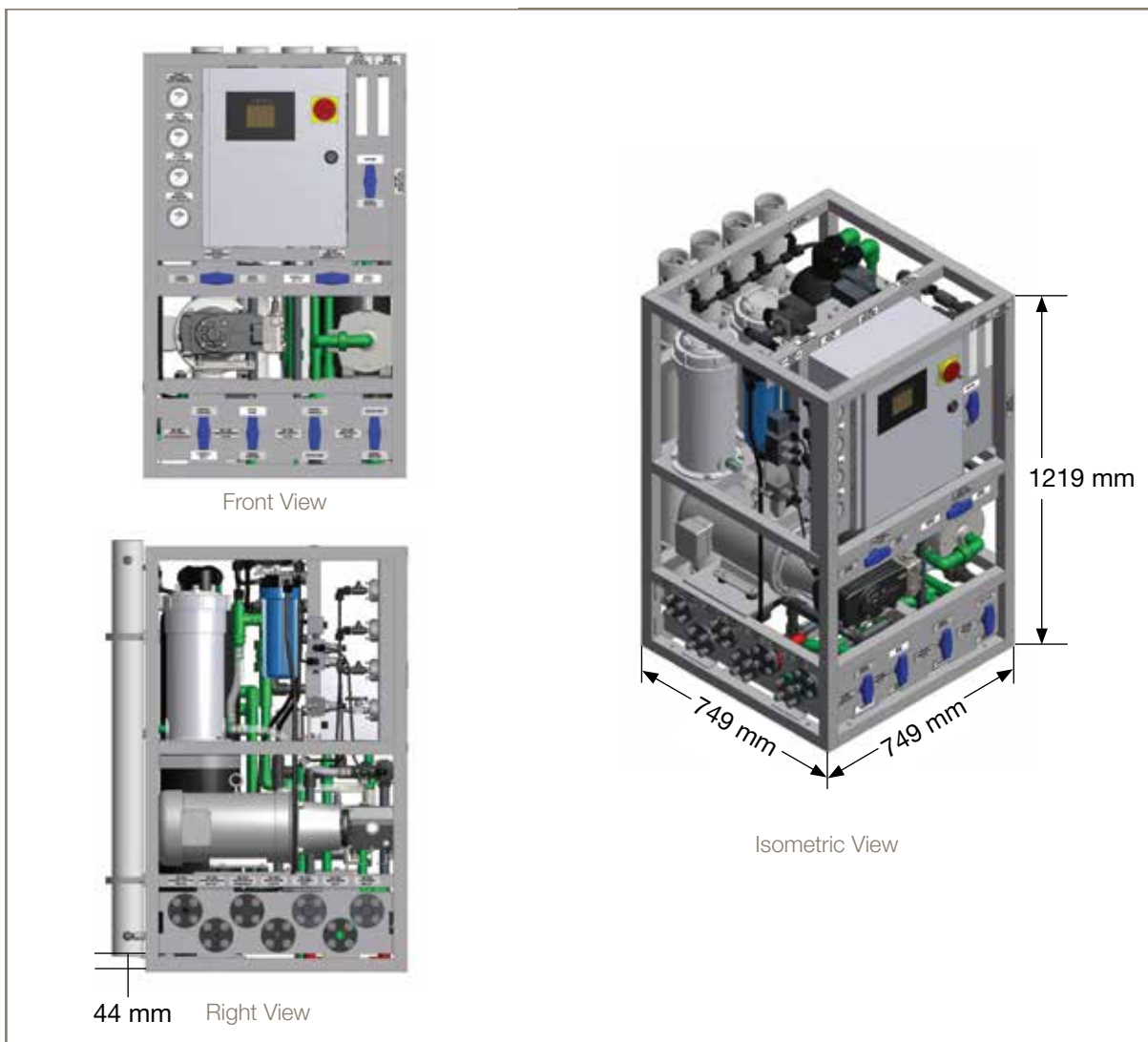

# Coral Sea Series

State-of-the-art versatile design



Operators will get more out of the new Coral Sea Series of watermakers. Designed in three different configurations, the Coral Sea Series offers flexible installation options, a choice of basic or digital controller configurations, and the reliability, safety and quality that could only be delivered by Parker Sea Recovery

## **Vertical, horizontal or modular configurations**

The Coral Sea Series is available in three different design configurations that accommodate any space. The vertical and horizontal compact aluminum frames are lightweight and corrosion resistant. The modular design allows individual component mounting, perfect for retrofits or new builds.

## **Industrial PLC control**

Integrated performance monitoring and optimization software allows the Coral Sea to display local warnings of potential problems before they become significant performance issues. A one-touch automatic start up/ shutdown function lets operators walk away knowing the system will continue to run at peak efficiency.



## **Product features**

- **Small-footprint, large-volume production, from 10.59 to 25.73 cubic meters per day**
- **Radial axial pump does not require oil change**
- **Basic and digital controller options**
- **Industrial PLC control**
- **User-friendly color touchscreen**
- **Optional ethernet/MODBUS communication**

## Coral Sea System Specifications

| Model | No. of Vessels | Vessel Size | Production / Hour | Production / 24 Hrs. | Weight |
|-------|----------------|-------------|-------------------|----------------------|--------|
| 2800  | 4              | 76.2mm      | 442 lit           | 10.59 m <sup>3</sup> | 445 kg |
| 3600  | 4              | 76.2mm      | 568 lit           | 13.62 m <sup>3</sup> | 445 kg |
| 4200  | 3              | 101.6mm     | 662 lit           | 15.89 m <sup>3</sup> | 445 kg |
| 5200  | 4              | 101.6mm     | 820 lit           | 19.68 m <sup>3</sup> | 454 kg |
| 6200  | 5              | 101.6mm     | 978 lit           | 23.46 m <sup>3</sup> | 463 kg |
| 6800  | 6              | 101.6mm     | 1,073 lit         | 25.73 m <sup>3</sup> | 477 kg |

\*All models available in Vertical, Horizontal, or Modular configurations

## Electrical Requirements

| Model 2800 - 3600  |         |         |     | Model 4200 - 6800  |         |         |     |
|--------------------|---------|---------|-----|--------------------|---------|---------|-----|
| Power              | HP Pump | Booster | FLA | Power              | HP Pump | Booster | FLA |
| 220 / 50 Hz / 1 PH | 5.5 KW  | 1.5 KW  | 48  | 230 / 60 Hz / 1 PH | N/A     | N/A     | N/A |
| 220 / 50 Hz / 3 PH | 5.5 KW  | 1.5 KW  | 36  | 208 / 60 Hz / 3 PH | 7.5 KW  | 1.5 KW  | 39  |
| 380 / 50 Hz / 3 PH | 5.5 KW  | 1.5 KW  | 17  | 230 / 60 Hz / 3 PH | 7.5 KW  | 1.5 KW  | 21  |

## Coral Sea Dimensions

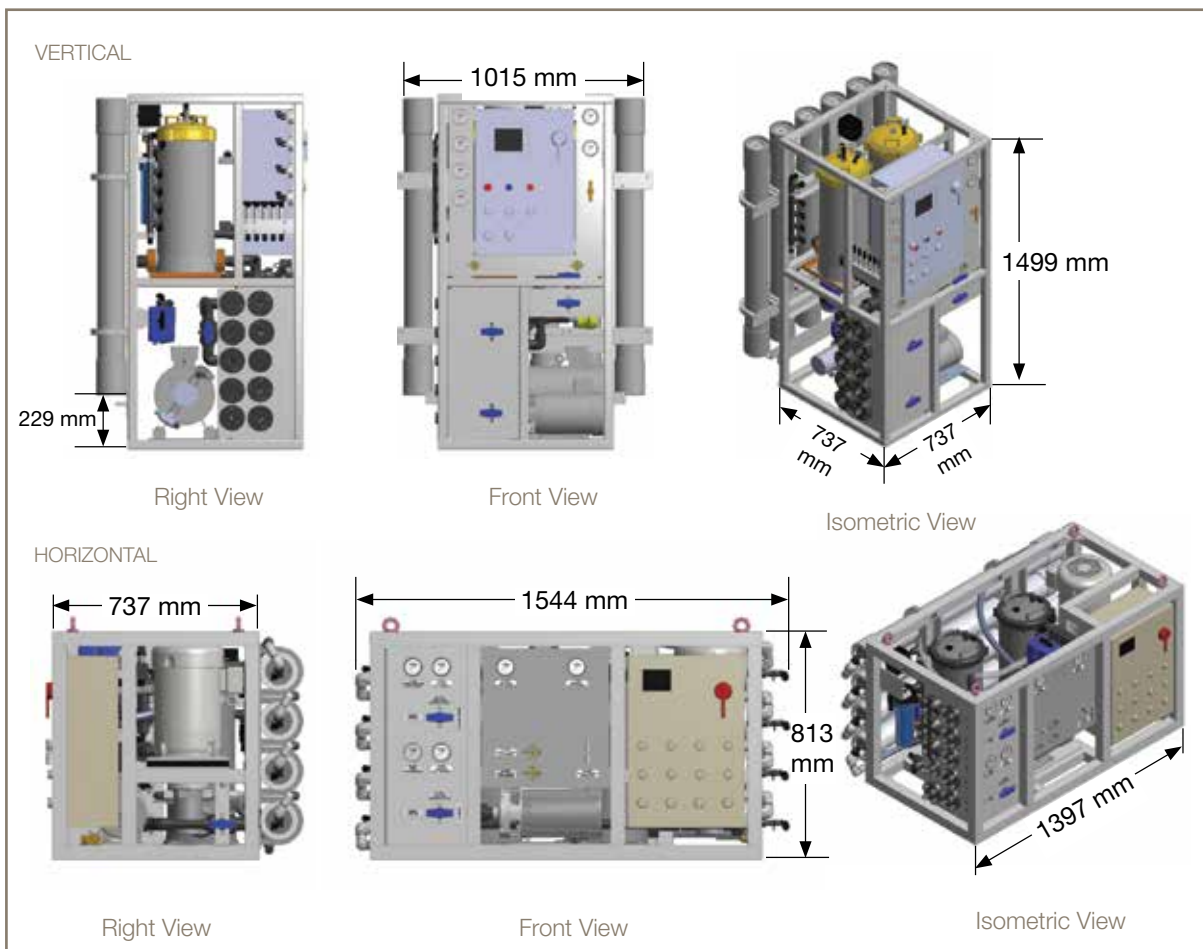

# Tasman Sea T-2

Reliable service, new modern controls



The Tasman Sea T-2 offers semi-automatic to fully automatic configurations - all complete with touch-screen controls and optional Ethernet and MODBUS remote communication. The Tasman Sea T-2 requires minimal maintenance and is backed by a global team of factory-trained technicians. Parker Sea Recovery continues the tradition of using high-quality parts that have been tested and proven to exceed industry safety standards, giving customers the confidence of choosing the world's most trusted watermaker.

## Choose the level of control

Choose from basic, semi-automatic or fully automatic control options. The basic control option features a performance- and error-detection function that displays multiple different user warning messages, helping to prevent major maintenance issues.

Parker Sea Recovery's integrated performance monitoring and optimization software allows the Tasman Sea to display local warnings of potential problems before they become significant performance issues. Its one-touch automatic start up/shutdown function lets operators walk away knowing the system will continue to run at peak efficiency.



## Product features

- **Small footprint, large volume production, from 25 to 90 cubic meters per day**
- **Radial axial pump does not require oil change**
- **Available with basic, semi-automatic and automatic controller options**
- **Industrial PLC control User-friendly color touchscreen**
- **Optional ethernet/MODBUS communication**

## Tasman Sea System Specifications

| Model            | No. of Vessels | Membrane Configuration | Production / Hour   | Production / 24 Hrs. | Weight   |
|------------------|----------------|------------------------|---------------------|----------------------|----------|
| 25m <sup>3</sup> | 1              | Single                 | 1.05 m <sup>3</sup> | 25 m <sup>3</sup>    | 861 kg   |
| 45m <sup>3</sup> | 2              | Single                 | 1.87 m <sup>3</sup> | 45 m <sup>3</sup>    | 953 kg   |
| 45m <sup>3</sup> | 1              | Double                 | 1.87 m <sup>3</sup> | 45 m <sup>3</sup>    | 953 kg   |
| 60m <sup>3</sup> | 3              | Single                 | 2.49 m <sup>3</sup> | 60 m <sup>3</sup>    | 998 kg   |
| 72m <sup>3</sup> | 4              | Single                 | 2.99 m <sup>3</sup> | 72 m <sup>3</sup>    | 1,089 kg |
| 72m <sup>3</sup> | 2              | Double                 | 2.99 m <sup>3</sup> | 72 m <sup>3</sup>    | 1,089 kg |
| 90m <sup>3</sup> | 6              | Single                 | 3.74 m <sup>3</sup> | 90 m <sup>3</sup>    | 1,089 kg |
| 90m <sup>3</sup> | 3              | Double                 | 3.74 m <sup>3</sup> | 90 m <sup>3</sup>    | 1,089 kg |

## Electrical Requirements

Systems: 25m<sup>3</sup> - 90m<sup>3</sup>

| Power              | HP Pump | Booster Pump | FLA |
|--------------------|---------|--------------|-----|
| 220 / 50 Hz / 1 PH | 18.5 KW | 5.5 KW       | 90  |
| 380 / 50 Hz / 3 PH | 18.5 KW | 5.5 KW       | 52  |
| 440 / 50 Hz / 3 PH | 18.5 KW | 5.5 KW       | 47  |

## Tasman Sea Dimensions

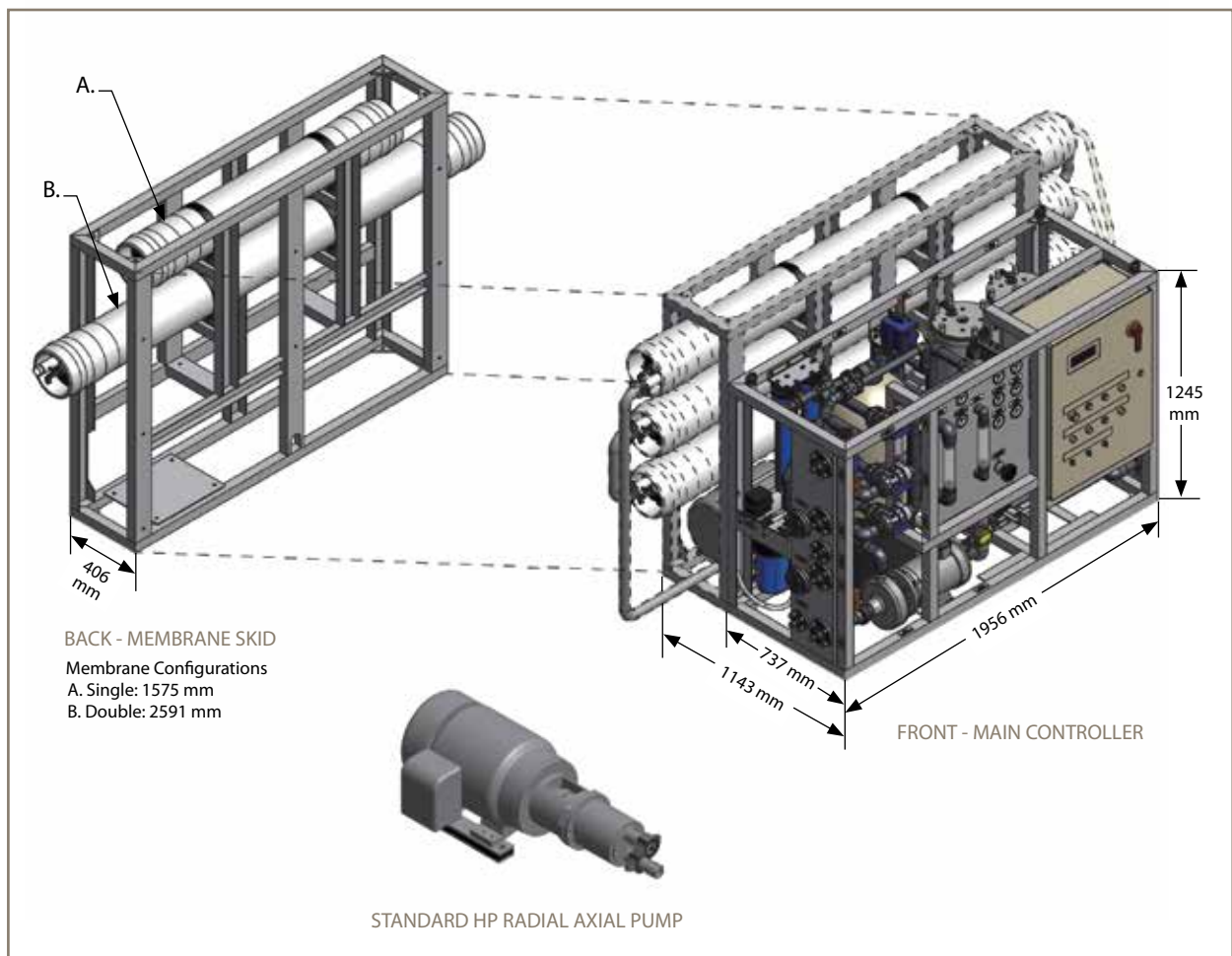

# North Sea Modular

Easy installation, large production, complete control



In the effort to accommodate the needs of the retrofit market, Parker Sea Recovery has created the North Sea Modular Series. The North Sea Modular Series provides a reliable source of fresh water at large production capacities, with minimal space and maintenance requirements. Its configuration provides maximum utility of space while incorporating ease of control and safety standards.

## Modular configuration - perfect for retrofit

The North Sea Modular Series is built to fit through waterproof doors and hatches. This conserves the vessel's original form by virtually eliminating the need for cutting - saving time and money.

Perfect for retrofit or new builds, the North Sea Modular's separate component installation feature accommodates space restrictions. Its robust aluminum frame allows access from any angle for easy maintenance.



## Product features

- **Small footprint, large volume production, from 45 to 200 cubic meters per day**
- **Radial axial pump does not require oil change**
- **Available with basic, semi-automatic and automatic controller options**
- **Industrial PLC control**
- **User-friendly color touchscreen**
- **Optional ethernet/MODBUS communication**



## North Sea Modular System Specifications

| Model             | No. of Vessels | Membrane Configuration | Production / Hour   | Production / 24 Hrs. | Weight   |
|-------------------|----------------|------------------------|---------------------|----------------------|----------|
| 45m <sup>3</sup>  | 1              | Double                 | 1.87 m <sup>3</sup> | 45 m <sup>3</sup>    | 1,679 kg |
| 85m <sup>3</sup>  | 2              | Double                 | 3.53 m <sup>3</sup> | 85 m <sup>3</sup>    | 1,815 kg |
| 105m <sup>3</sup> | 3              | Double                 | 4.37 m <sup>3</sup> | 105 m <sup>3</sup>   | 1,951 kg |
| 145m <sup>3</sup> | 4              | Double                 | 6.03 m <sup>3</sup> | 145 m <sup>3</sup>   | 2,177 kg |
| 175m <sup>3</sup> | 6              | Double                 | 7.29 m <sup>3</sup> | 175 m <sup>3</sup>   | 2,178 kg |
| 175m <sup>3</sup> | 4              | Triple                 | 7.29 m <sup>3</sup> | 175 m <sup>3</sup>   | 2,450 kg |
| 200m <sup>3</sup> | 6              | Triple                 | 8.33 m <sup>3</sup> | 200 m <sup>3</sup>   | 2,858 kg |

## Electrical Requirements

| System                                | Data                       | 220/50Hz/3PH | 380/50Hz/3PH | 440/50Hz/3PH |
|---------------------------------------|----------------------------|--------------|--------------|--------------|
| 45m <sup>3</sup>                      | Full Horse Power - HP Pump | 18.5 KW      | 18.5 KW      | 18.5 KW      |
|                                       | Full Horse Power - Booster | 5.5 KW       | 5.5 KW       | 5.5 KW       |
|                                       | FLA                        | 93           | 54           | 47           |
| 85m <sup>3</sup> • 105 m <sup>3</sup> | Full Horse Power - HP Pump | 18.5 KW      | 18.5 KW      | 18.5 KW      |
|                                       | Full Horse Power - Booster | 5.5 KW       | 5.5 KW       | 5.5 KW       |
|                                       | FLA                        | 93           | 54           | 47           |
| 145m <sup>3</sup> - 200m <sup>3</sup> | Full Horse Power - HP Pump | 37 KW        | 37 KW        | 37 KW        |
|                                       | Full Horse Power - Booster | 5.5 KW       | 5.5 KW       | 5.5 KW       |
|                                       | FLA                        | 135          | 79           | 68           |

## North Sea Modular Dimensions

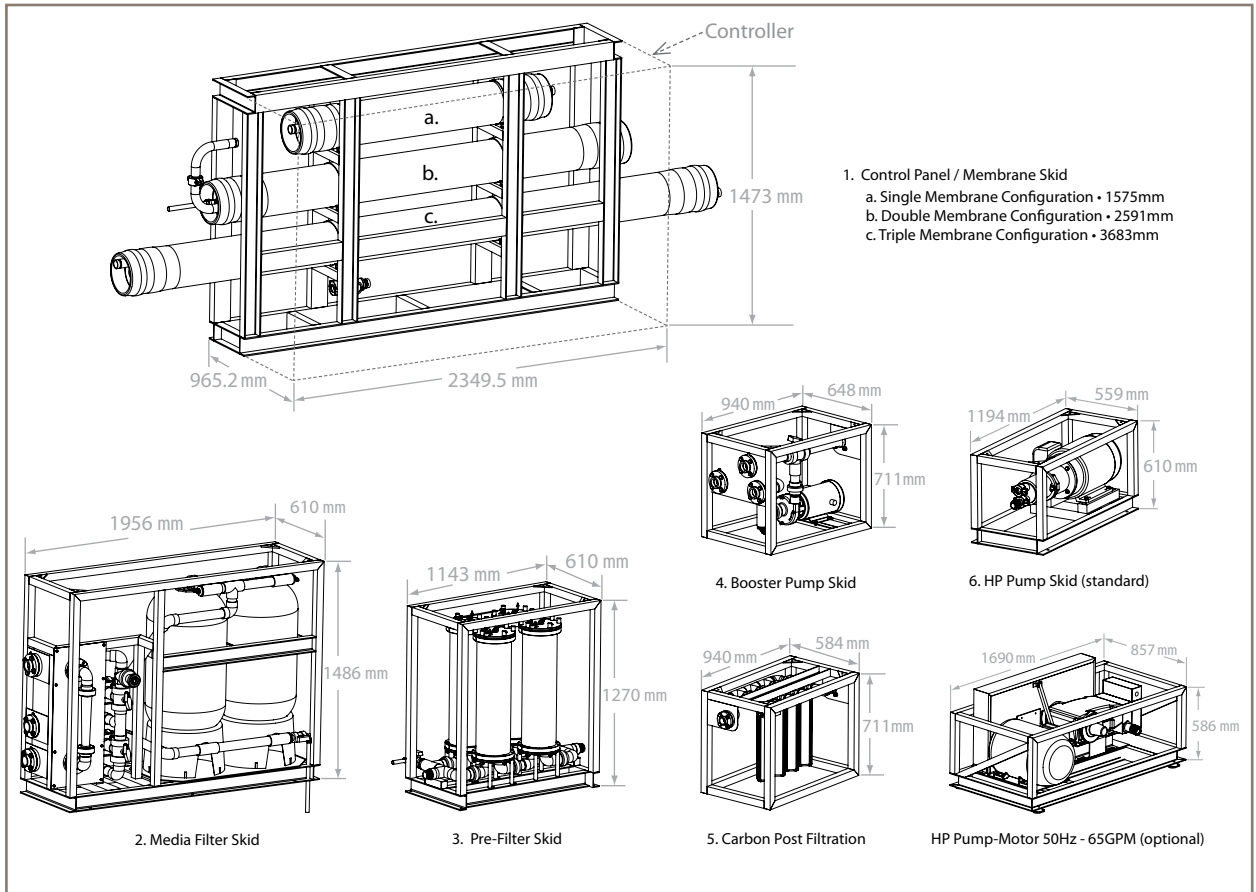

# North Sea N-2 Series

The reliable choice for unlimited fresh water production



The North Sea N-2 Series is the top choice of the offshore and commercial marine industry. It has the capacity to provide up to 200 metric tons of fresh water per day. With minimal space and maintenance requirements, the new North Sea N-2 has multiple controller configuration options, and provides maximum utility of space while incorporating ease of control and safety standards.

## Choose the level of control

Choose from basic, semi-automatic, or fully automatic control options. The basic control option features a performance- and error-detection function that displays multiple user warning messages to help prevent major maintenance issues.

The North Sea N-2 high pressure pump is the most compact and efficient pump on the market. This HP pump has flexible installation options that don't require frames, belt drives or gear boxes. The HP pump is water lubricated, corrosion resistant (Super Duplex), and completely eliminates membrane fouling caused by oil leaks. This innovative HP pump provides constant flow regardless of variations in pressure while delivering a total efficiency of up to 97 percent.



## Product features

- **Produces 45 to 200 cubic meters per day**
- **Radial axial pump does not require oil change**
- **Available with basic, semi-automatic and automatic controller options**
- **Industrial PLC control**
- **User-friendly color touchscreen**
- **Optional ethernet/MODBUS communication**

## North Sea N-2 System Specifications

| Model             | No. of Vessels | Membrane Configuration | Production / Hour   | Production / 24 Hrs. | Weight   |
|-------------------|----------------|------------------------|---------------------|----------------------|----------|
| 45m <sup>3</sup>  | 1              | Double                 | 1.87 m <sup>3</sup> | 45 m <sup>3</sup>    | 1,679 kg |
| 85m <sup>3</sup>  | 2              | Double                 | 3.53 m <sup>3</sup> | 85 m <sup>3</sup>    | 1,815 kg |
| 105m <sup>3</sup> | 3              | Double                 | 4.37 m <sup>3</sup> | 105 m <sup>3</sup>   | 1,951 kg |
| 145m <sup>3</sup> | 4              | Double                 | 6.03 m <sup>3</sup> | 145 m <sup>3</sup>   | 2,177 kg |
| 175m <sup>3</sup> | 6              | Double                 | 7.29 m <sup>3</sup> | 175 m <sup>3</sup>   | 2,178 kg |
| 175m <sup>3</sup> | 4              | Triple                 | 7.29 m <sup>3</sup> | 175 m <sup>3</sup>   | 2,450 kg |
| 200m <sup>3</sup> | 6              | Triple                 | 8.33 m <sup>3</sup> | 200 m <sup>3</sup>   | 2,858 kg |

## Electrical Requirements

| System                                | Data                       | 220/50Hz/3PH | 380/50Hz/3PH | 440/50Hz/3PH |
|---------------------------------------|----------------------------|--------------|--------------|--------------|
| 45m <sup>3</sup>                      | Full Horse Power - HP Pump | 18.5 KW      | 18.5 KW      | 18.5 KW      |
|                                       | Full Horse Power - Booster | 5.5 KW       | 5.5 KW       | 5.5 KW       |
|                                       | FLA                        | 93           | 54           | 47           |
| 85m <sup>3</sup> • 105 m <sup>3</sup> | Full Horse Power - HP Pump | 18.5 KW      | 18.5 KW      | 18.5 KW      |
|                                       | Full Horse Power - Booster | 5.5 KW       | 5.5 KW       | 5.5 KW       |
|                                       | FLA                        | 93           | 54           | 47           |
| 145m <sup>3</sup> - 200m <sup>3</sup> | Full Horse Power - HP Pump | 37 KW        | 37 KW        | 37 KW        |
|                                       | Full Horse Power - Booster | 5.5 KW       | 5.5 KW       | 5.5 KW       |
|                                       | FLA                        | 135          | 79           | 68           |

## North Sea N-2 Dimensions

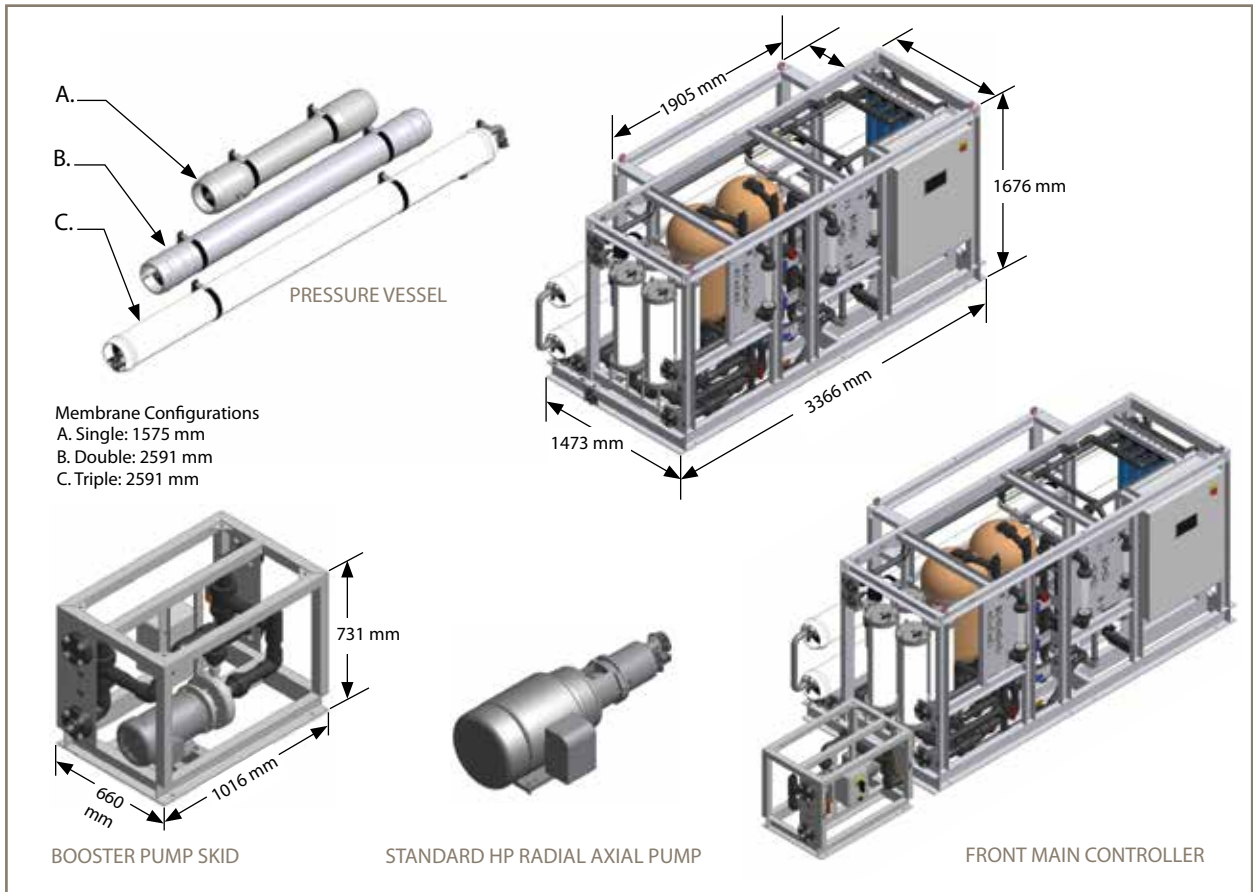

# Atlantic Sea Series

Safe, reliable and supported  
anywhere in the world



The Atlantic Sea is Parker Sea Recovery's largest series of SWRO systems. Its features include a small footprint and fully automatic controls with the capability to produce up to 1,200 metric tons per day. The Atlantic Sea also boasts the lowest consumption of energy per ton of water produced. This system is perfect for those who require an unlimited amount of fresh water anywhere at anytime.

## Efficiently productive

From its fully automated controller to its low maintenance HP pump and its I-Save energy recovery system, the Atlantic Sea flawlessly delivers high production capacities. Its automated controller is easy to operate and allows real-time remote monitoring of essential system functions.

The Atlantic Sea's high pressure pump is the most compact and efficient pump on the market. Its flexible installation doesn't require frames, belt drives or gear boxes. The HP pump is corrosion resistant and completely eliminates oil leaks and membrane fouling caused by oil leaks.

The Atlantic Sea is capable of instant-on start-up that allows the system to produce usable, fresh water within minutes.



## Product features

- **Mega production - up to 1,200 metric tons per day**
- **Digital control with standard MODBUS**
- **Low-maintenance HP pump**
- **I-Save energy recovery system**
- **One-touch start up with instant-on feature**

## Atlantic Sea System Specifications

| System Production   | Energy Recovery Available / Type | No. of Membranes | Production / Hour | Production / 24 Hrs. | Estimated Energy Savings Per M <sup>3</sup> of Water Produced |
|---------------------|----------------------------------|------------------|-------------------|----------------------|---|
| 250 M <sup>3</sup>  | YES / I-SAVE                     | 12               | 10,417 lit        | 250,000 lit          | 40%   |
| 300 M <sup>3</sup>  | YES / I-SAVE                     | 16               | 12,500 lit        | 300,000 lit          | 40%   |
| 400 M <sup>3</sup>  | YES / I-SAVE                     | 20               | 16,667 lit        | 400,000 lit          | 44%   |
| 500 M <sup>3</sup>  | YES / I-SAVE                     | 30               | 20,833 lit        | 500,000 lit          | 44%   |
| 600 M <sup>3</sup>  | YES / I-SAVE                     | 50               | 25,000 lit        | 600,000 lit          | 44%   |
| 750 M <sup>3</sup>  | YES / I-SAVE                     | 60               | 31,250 lit        | 750,000 lit          | 44%   |
| 1000 M <sup>3</sup> | YES / I-SAVE                     | 100              | 41,667 lit        | 1,000,000 lit        | 48%   |
| 1200 M <sup>3</sup> | YES / I-SAVE                     | 120              | 50,000 lit        | 1,200,000 lit        | 49%   |

## Atlantic Sea Dimensions

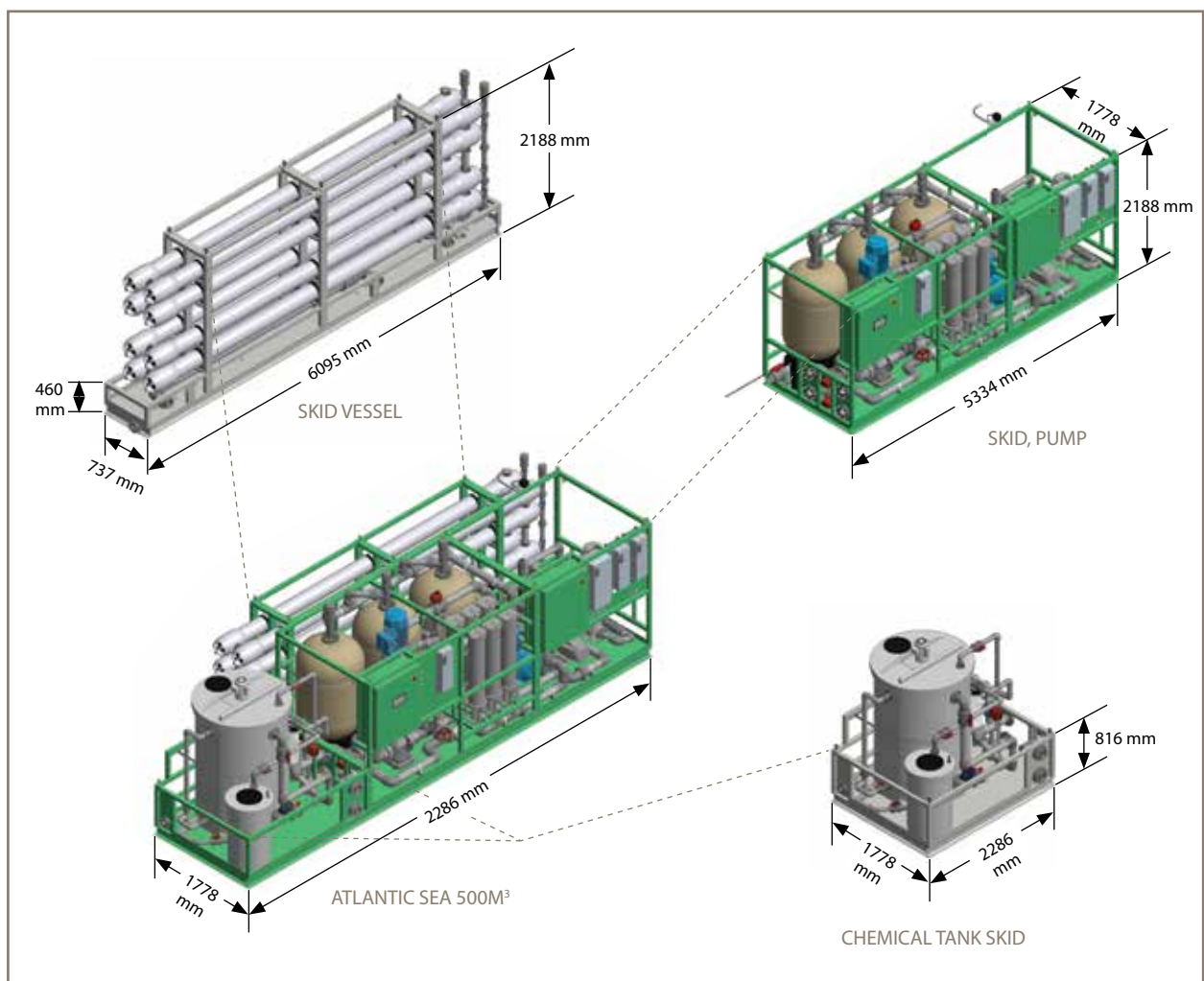

# Customized Systems

Custom designed to meet your needs

Parker Sea Recovery's advanced water systems are capable of being customized to the special needs of individual customers. The company works closely with customers to meet all specifications, whether it's for customized parts, production capacities or a complete customized re-design. Parker Sea Recovery's customized reverse-osmosis water systems provide the same advanced technologies as standard systems and are delivered and commissioned to any location in the world. A typical delivery time for customized systems ranges from 10 to 12 weeks.

## Design

After receiving specifications, Parker Sea Recovery's engineers and system designers create a system that is designed to meet or exceed client specifications. Once the final design is approved by the customer, the dedicated Parker Sea Recovery team of specialists begins building a system that will look and function to agreed standards.

## Build

Customized systems are given as much attention as our standard systems. Always at

the lead in industry standards, Parker Sea Recovery water systems are built with quality components and materials, incorporating advanced electronics and modern user interfaces that allow ease of operation and maintenance. The Parker Sea Recovery development process also includes extensive testing to the system will run flawlessly and adhere to safety standards once in full operation.

## Delivery and Commissioning

Parker Sea Recovery's local sales representatives work closely with customers to ensure their system is delivered and commissioned promptly and properly. With service specialists located in every part of the world, Parker Sea Recovery has local assistance always at the ready. Typically a completely re-designed custom system can be delivered in about 12 weeks.



# Accessories and Consumables



**Fresh Water Flush**  
Prolong membrane life at the touch of a button.



**pH Neutralizer**  
Restore product water to a neutral state or level.



**Hydrocyclone Separator**  
Has no filters or moving parts and extends the life of pre-filters and elements.



**Chemical Cleaning Tank**  
Restore membrane productivity and reduce bio-fouling.



**UV Sterilizer**  
Eliminates 99.8 percent of bacteria and viruses from the feed water.



**Chemical Injection**  
Control the chemistry of the feed water to reduce and prevent fouling..



**Media Filter**  
Traps suspended solids larger than 30 microns. Helps extend pre-filter element life.

## Consumables and Spares

Only Parker Sea Recovery's genuine replacement consumables and spares will ensure the quality and function of each Parker Sea Recovery watermaker system. Cleaning and storage compounds help prolong the life of the watermaker, and eliminate unnecessary buildup that can lead to extra maintenance. Contact a Parker Sea Recovery dealer to order spare replacements.



**To find a dealer or for service and parts, contact Parker Sea Recovery**  
Tel: 1 (800) 354-2000 | Email: [sales@searecovery.com](mailto:sales@searecovery.com)

# Worldwide Agents and Dealers

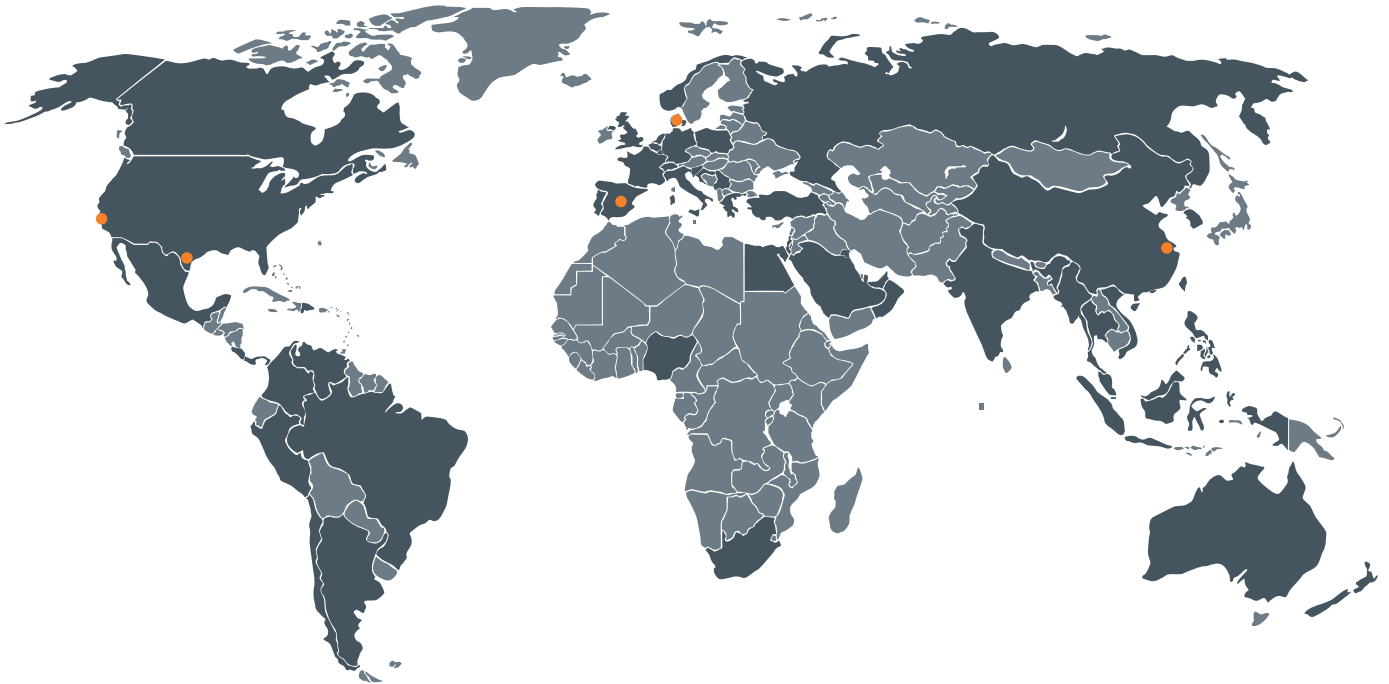

● Local Factory Sales Offices

■ Agents and Distributors

Visit our website to find a dealer, agent or service technician near you.

[www.searecovery.com](http://www.searecovery.com)

Authorized Representative:



Parker Hannifin Corporation

**Sea Recovery**

2630 E. El Presidio St.

Carson, CA 90810

Tel: 1 310 637 3400

Fax: 1 310 637 3430

[srcsales@searecovery.com](mailto:srcsales@searecovery.com)